



We Co., Ltd.

<http://www.wemodel.com.tw/>

MADE IN TAIWAN



WEM4-SERIES AUTOMATIC ELECTRIC GUN

操作手冊指導手冊

HANDLING CAUTION AND INSTRUCTION MANUAL

(分離式)

KATANA
M4, RIS,
RAPTOR



WEM4-E01
WEM4A1

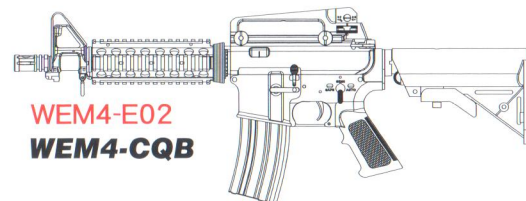

WEM4-E02
WEM4-CQB



WEM4-E03
WEM4-RIS

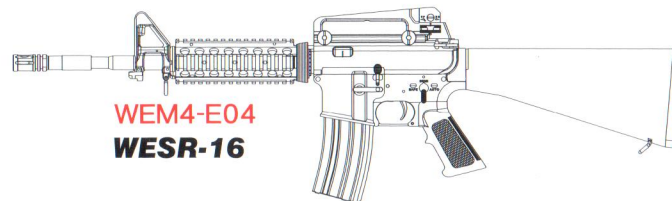

WEM4-E04
WESR-16



WEM4-E06
WEM4-R.A.R.S

適合年齡18歲以上使用 User restricted to 18 year of age or older.



注意
WARNING

使用前請務必詳讀此說明書
Always read through this manual before operating.

目錄

注意事項	2
NOTES	2
1.各部名稱	3
COMPONENT NAME	3
2.保險說明	4
SELECTOR LEVER & SAFETY SETTING	4
3.電池的安裝	5
SETTING BATTERY	5
4.彈匣的安裝	6
SETTING MAGAZINE	6
5.準星與照門的調整	7
ADJUSTABLE FRONT SIGHT AND REAR SIGHT	7
6.拆裝和維修	8
DISASSEMBLY AND MAINTENANCE	8
7.可動部的說明	9
MOVABLE PARTS	9
8.射擊	11
FIRING	11
9.可變上旋系統的說明	13
VARIABLE HOP-UP SYSTEM	13
10.分解圖、零件表	15
PARTS LIST	15
11.故障診斷	18
TROUBLE CLINIC	18



警告
WARNING

在操作本產品之前，請務必詳讀此說明書
Always read through this manual before operating.

★正確使用空氣軟槍，可享受愉快的射擊，但是錯誤的使用方法非常危險，務必遵守注意事項。
□ Miss handle the airsoft gun may condition serious injure or death. Please read the safety instruction before use.

□ **Caution!**

▲ **PRECAUTION**
NE PAS UTILISER D'AUTRES
PROJECTILEE QUE CEUX FOURNIS.

△ **VORSICHT**

Ausschliesslich fur diese Pistole bestimmte
Munition verwenden. (6.0mm Kunststoffkugeln)
○ **Fare attenzione**



★射擊時最好戴護目鏡

□ Be sure to wear shooting glasses or Goggle when shooting.

▲ Toujours porter des lunettes de tir ou de protection quand vous tirez.

△ Zum Schiessen stets eine Schutzbrille tragen.

■ Asegures de llevar puestas las gafas de proteccion cuando dispere.

○ Assicurarsi di indossare lenti di Protezione quando si spara



★不用時要把槍置於高處
(小孩拿不到的高處)

□ Put the gun beyond the reach of kids.

▲ Tenir hors de portee des enfants.

△ Pistole immer kindersicher aufbewahren.

■ Ponga la pistola fuera del alcance de los ninos.

○ Tenere fuori Dalla portata dei bambini.

★不可用眼睛探視槍

□ Don't peep at the muzzle.

▲ Ne jamais regarder dans le canon.

△ Nie in den lauf schauen.

■ Jamas mire por el canon

○ Non guardare mai dentro la canna.



★不可朝人射擊

□ Don't aim at people even if it is unloaded.

▲ Ne jamais viser quelqu'un meme si votre pistolet est vide.

△ Auch bei spiel-und Sportwaffen besteht Verletzungsgefahr. Auch ungeladen nie auf einen Menschen oder ein Tier richten!

■ No apunte a personas, incluso descargado.

○ Non puntare mai verso le persone anche se la pistola scarica.



★射擊的瞬間，才可以把手指接近扳機擊扣

□ Don't touch the trigger until the moment of shooting.

▲ Ne jamais appuyer sur la gachette le rearmement.

△ Abzug erst dann berühren, wenn Sie zum Schiessen bereit sind.

■ No toque el gatillo hasta el momento del disparo.

○ Non toccare il grilletto fino al momento di sparare.



★確定射擊的方向均安全後才可以射擊

□ After making sure that there is nobody nearby.

▲ Toujours etre sur qu'il n y a personne dans la trajectoire de votre tir.

△ Vergewissern Sie sich vor dem Schiessen stets, dass niemand getroffen werden kann.

■ Antes de apuntar aseguese que no hay nadie cerca.

○ Assicurarsi sempre che non ci sia nessuno sulla traiectoria di tiro.



★避免粗魯的動作，發生危險

□ Avoid a rough operation.

▲ Ne jamais jeter le pistolet quand il est arme.

△ Geladene Waffe stets mit Respekt Behandln. Nicht werfen oder unsanft Jandhaben.

■ No tire ni lance la pistola, se puede disparar.

○ Evitare azioni brusche.



★不使用時，應將彈匣取出，並取下子彈

□ When the gun is not in use, remove the magazine and unload BB pellets.

▲ Quand vous ne l'utilisez plus, bien Faire attention de retirer le chargeur et de le desamer.

△ Zum Aufbewahren Magazin entfernen und Kugeln herausnehmen.

■ Cuando no se este utilizando la pistola, saque todas las bolas.

○ Quando l'arma non e in uso, estrarre il caricatore e scaricare i pallini.



1. 各部名稱

COMPONENT NAME

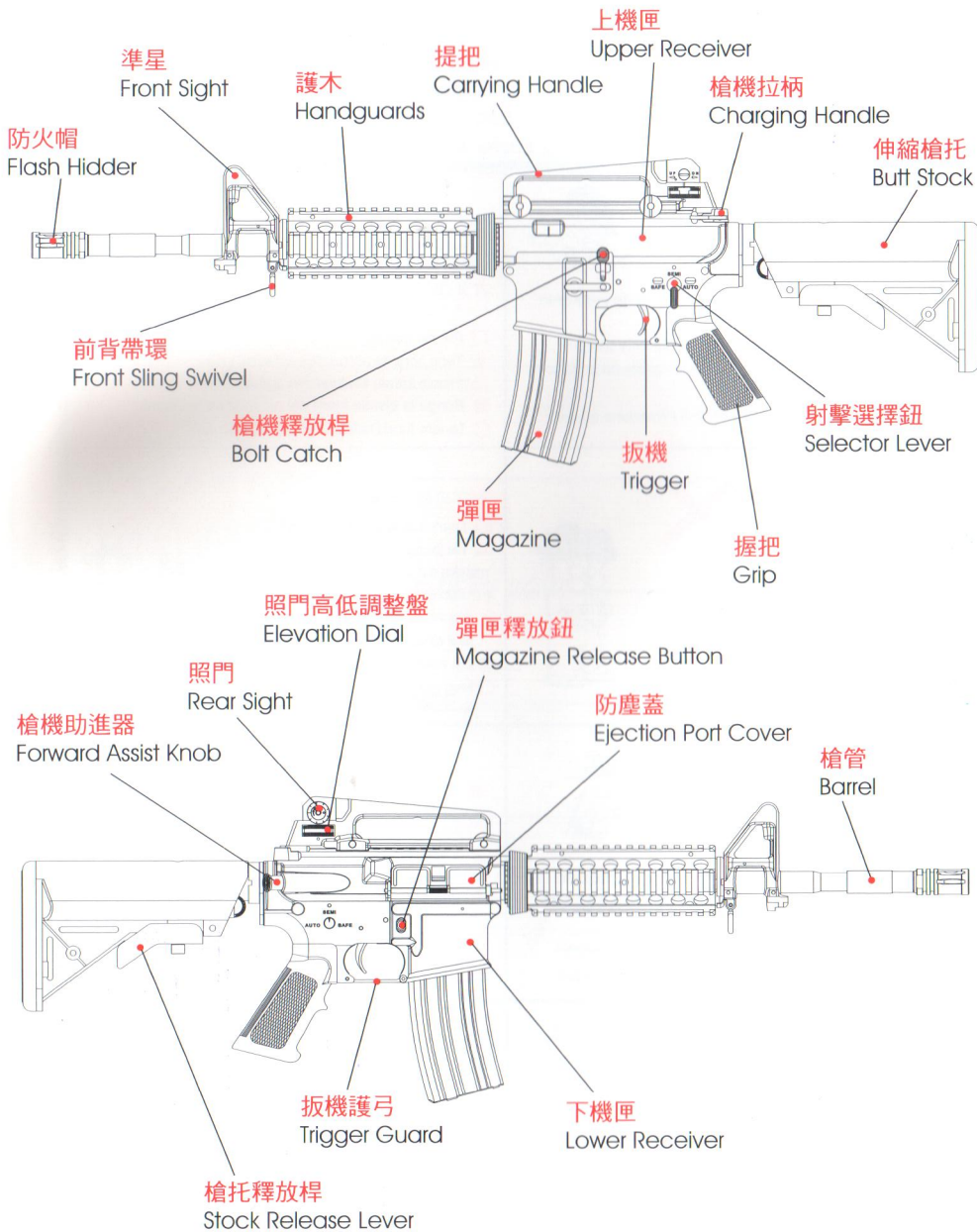

2. 保險說明

SELECTOR LEVER & SAFETY SETTING

※ 選擇鈕未扳至正確位置有可能會導致射擊模式發生錯誤。

Set the selector correctly in position, otherwise, malfunction may occur.

1. 保險(無法扣動扳機)

不射擊或一般存放時，務必將選擇鈕設定至保險(SAFE)位置。

Safety setting(The trigger can not be pull)

Always set lever to the **SAFE** position when you are not firing the gun or during storage.

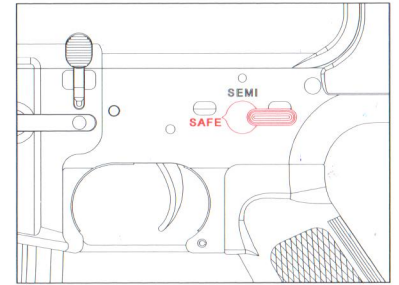

2. 半自動(單發)

選擇鈕設定至半自動(SEMI)位置，此時扣一次扳機只會發射一顆子彈。

Semi Auto(Single Shot)

Set lever to the **SEMI** position, The gun will fire one shot each time the trigger is pulled.

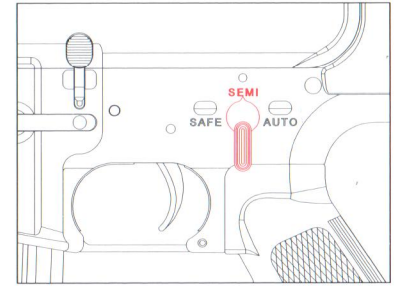

3. 全自動(連發)

選擇鈕設定至全自動(AUTO)位置，此時扣扳機不放會連續發射子彈。

Full Auto(Automatic Shot)

Set lever to the **AUTO** position, The gun will fire automatically while the trigger remains pulled.

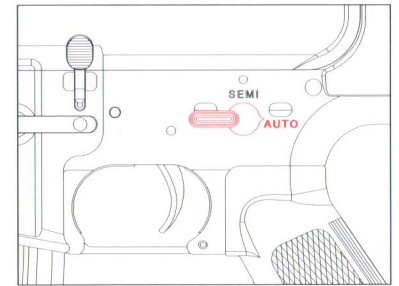

警告·注意 WARNING · CAUTION

- 請勿一邊扣動扳機一邊扳動選擇鈕，否則將導致故障，或發生意外。
Never operation the Selector while pulling the trigger. Otherwise malfunctions are possible, resulting in accidents.
- 在關保險狀態時，強制扣動扳機有可能會導致故障。
Pulling the trigger with the Selector being set to safe may damage the gun.

3. 電池的安裝

SETTING BATTERY

1. 推壓兩側卡榫並拆下槍托底板。
Push both side of the latch and remove the butt stock plate.

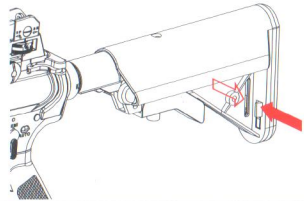

2. 打開電池蓋。
Open the battery cover.

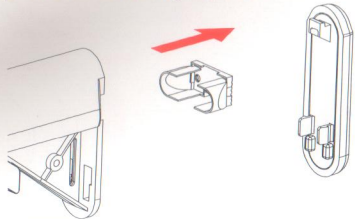

3. 將電池裝入槍托裡並接上接頭。
Insert the battery in the stock and connect the connector.

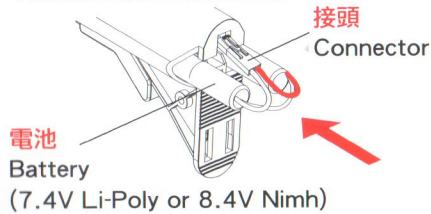

4. 裝回電池蓋及槍托底板。
Replace the battery cover and butt stock plate.

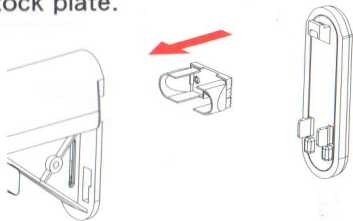

1. 拆除槍托組。
Remove the butt stock by pulling the stock lever and then slide it outwards.

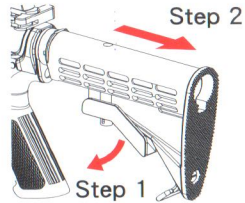

2. 取下托桿後蓋。
Remove the back cover of the buttstock tube.

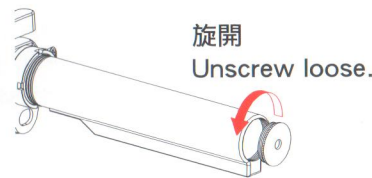

3. 將電池裝入並接上接頭。
Insert the battery and connect the connector.

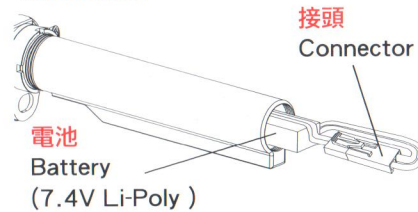

4. 安裝托桿後蓋及槍托組。
Installing the back cover and butt stock.

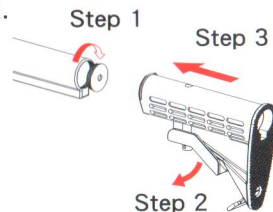

4. 彈匣的安裝

SETTING MAGAZINE

- ① 按壓彈匣釋放鈕並取下彈匣。
Press the magazine release button.
- ② 取下彈匣。(取下時請扶住彈匣，避免彈匣掉下損壞。)
Remove the magazine. (Support the magazine as it may drop.)

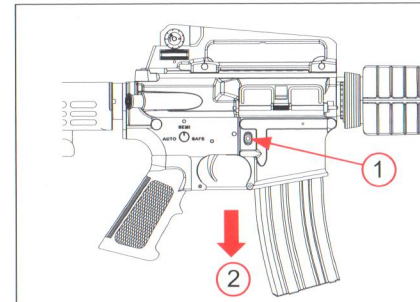

- ③ 將彈匣蓋打開並倒入BB彈。
Open the cover of magazine and insert BBs in to the magazine.

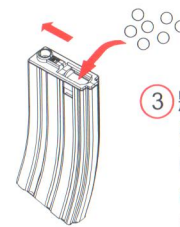

- ④ 轉動底部轉盤依箭頭方向將發條上緊直到聽到"喀喀"聲時則停止轉動。
Turn the gear at the bottom until heard click sound.

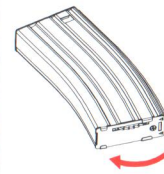

- ⑤ 正確將彈匣向上插入彈匣口連接牢固直到聽到"喀"一聲。
Make sure to set the magazine upwards and connect it firmly until heard a click sound.

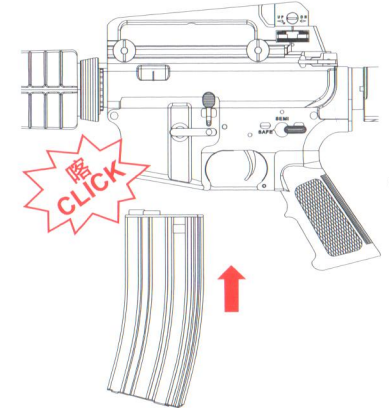

警告 ▪ 注意 WARNING ▪ CAUTION

- 請使用高品質BB彈在你的槍上，對因使用劣質或重量不足的BB彈產生的損壞件，本公司將不負保固責任。
Always use the high quality BB bullets in your air gun. We will not be held responsible for any damage incidents arising from use of poor quality or underweight BB bullets.

5. 準星與照門的調整

ADJUSTABLE FRONT SIGHT AND REAR SIGHT

準星的調整 Adjustable Front Sight.

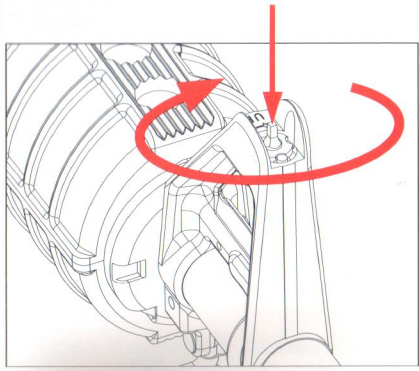

順時針方向旋轉: 瞄柱下降, 彈著點提高。
Turning clockwise: Down the sight post, raise up the bullet hitting point.

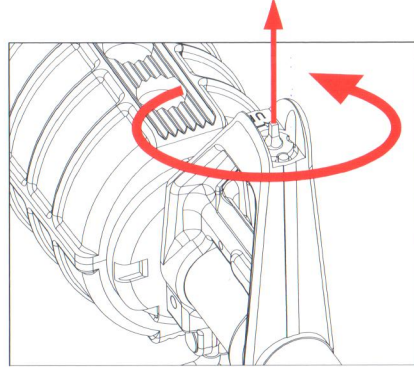

逆時針方向旋轉: 瞄柱上升, 彈著點下降。
Turning counterclockwise: Up the sight post, lowers the bullet hitting point.

照門的調整 Adjustable Rear Sight.

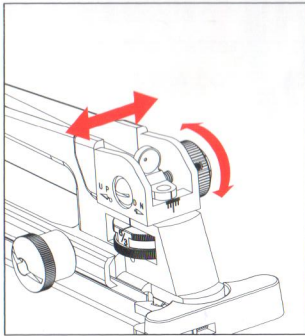

向前轉動: 照門向右移動, 彈著點向右。
向後轉動: 照門向左移動, 彈著點向左。
Forward: Move the sight to the right, bullet hitting to the right. Backward: Move the sight to the left, bullet hitting to the left.

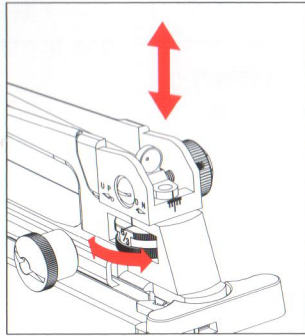

向前轉動: 照門向上移動, 彈著點提高。
向後轉動: 照門向下移動, 彈著點下降。
Forward: Up the sight, raise up the bullet hitting point. Backward: Down the sight, lowers the bullet hitting point.

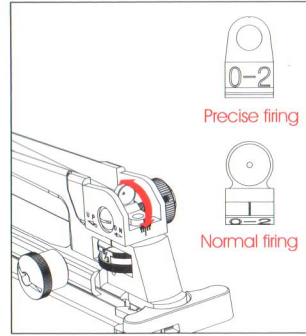

戰鬥瞄準器可以扳起與扳倒, 分正常射擊與精確射擊。
The firing sight can be flip up and down. Has separately normal firing and precise firing.

6. 拆裝和維修

DISASSEMBLY AND MAINTENANCE

※簡單的拆裝可以更換不同力量的汽缸組。

Simply disassemble is able to replace cylinder unit with different power.

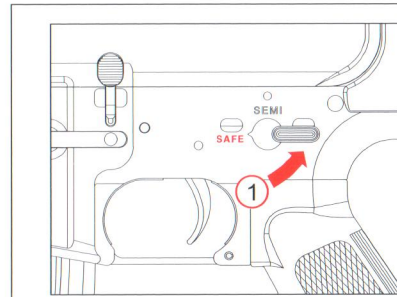

- ① 將射擊選擇鈕切換到安全模式並且同時釋放內部彈簧。
Set the selector lever to SAFE mode and the simultaneous release of an internal spring.

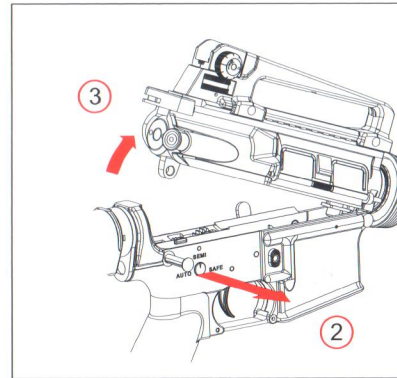

- ② 從另一側將後插梢推出 (伸出一點點在另一側) 或用螺絲起子推他們出來, 用手指拉出直到他們停止移動。
Push the Rear Pivot Pin from the other side of the gun (they protrude a little bit on the opposite side) or use screw driver to push it out and use fingernails to pull until they stop moving.
- ③ 將上機匣托起。
Open upper receiver.

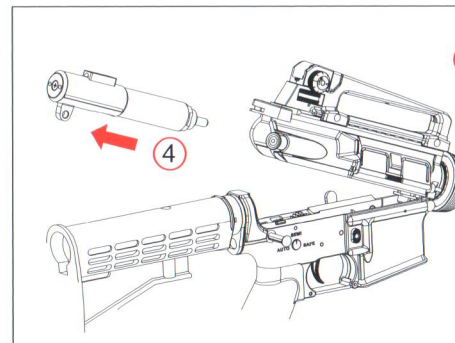

- ④ 汽缸組可以從上槍身抽出。
The cylinder unit can be drawn from the upper receiver.

警告 · 注意 WARNING · CAUTION

- 若選擇鈕未切換到安全模式, 後插梢則無法被拉出。
If the selector lever does not to safe mode, The rear pin can not be pulled out.

7.1 可動部的說明

MOVABLE PARTS

伸縮托操作 Operate the Telescoping Stock.

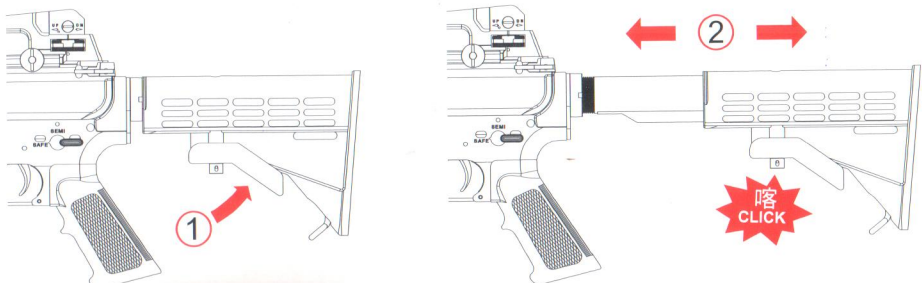

- 1 按壓彈匣釋放鈕並取下彈匣。
Press the stock release button.
- 2 調整槍托位置，有4段可調整。
Adjust the position of stock.(4 positions)

提把拆除操作 Operate the Carrying Handle take down.

- 1 鬆開兩顆旋鈕。
Loosened the knobs.
- 2 拉起提把。
Pulling up the carrying handle.

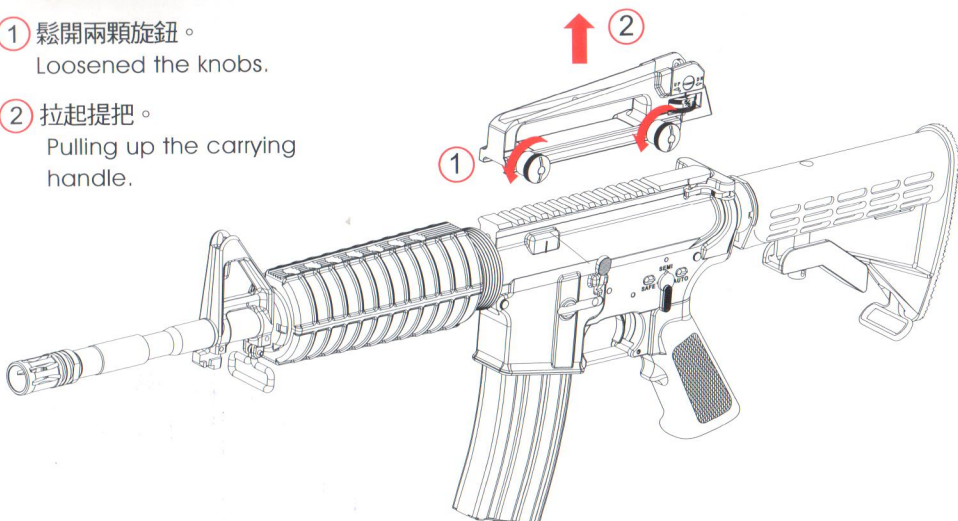

警告 ▪ 注意 **WARNING** ▪ **CAUTION**

- 操作伸縮托時，請小心勿被夾傷。
Be carefully don't get hurt your fingers when operating buttstock functions.

7.2 可動部的說明

MOVABLE PARTS

槍機拉柄,板機護弓與槍機助進器操作
Operate the Charging Handle, Trigger Guard and Forward Assist Knob.

槍機飾片
Dummy Bolt

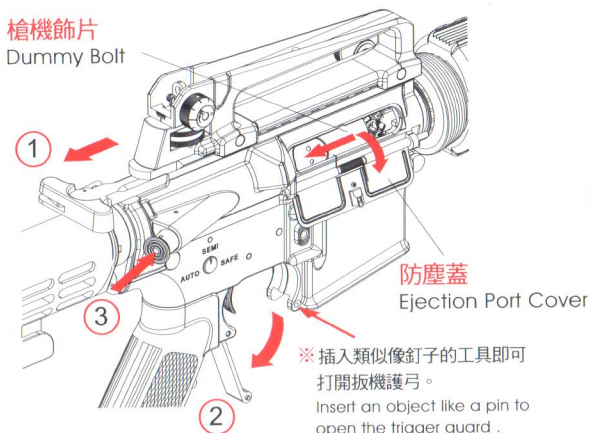

- 1 拉動槍機拉柄可打開防塵蓋，槍機飾片固定在後。
Pulling the Charging handle can opens the Ejection port cover, the dummy bolt will be fixed in rear.
- 2 扳機護弓可以打開或關起，用於冬天帶手套時便於扣扳機。
Trigger guard can be opened and closed. Used when you wear gloves in winter.
- 3 可推動槍機助進器。
Forward assist knob can be pushed.

※ 插入類似像釘子的工具即可
打開扳機護弓。
Insert an object like a pin to
open the trigger guard.

槍機釋放桿操作 Operate the Bolt Catch

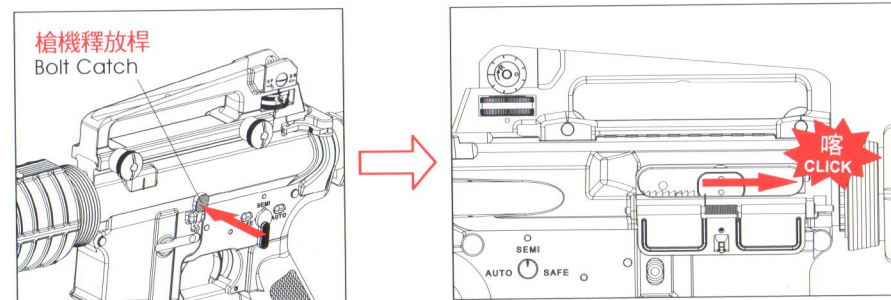

當槍機飾片固定在後時，按壓槍機釋放桿可以使槍機飾片釋放回復。
When the dummy bolt fixed in rear, press Bolt Catch can to release the dummy bolt.

警告 ▪ 注意 **WARNING** ▪ **CAUTION**

- 操作槍機拉柄與槍機釋放桿時，請小心勿被夾傷。
Be carefully don't get hurt your fingers when pulling the cahrging handle and .

8.1 射擊

FIRING

※充分確認安全後才可開始進行射擊 Confirm safety sufficiently before beginning firing.

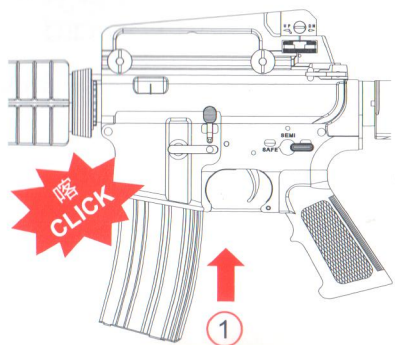

- ① 正確將彈匣向上插入彈匣口連接牢固直到聽到"喀"一聲。
Make sure to set the magazine upwards and connect it firmly until heard a click sound.

- ② 將射擊選擇鈕設定在半自動或全自動位置。

Set the position selector lever to SEMI or AUTO position.

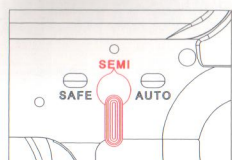

半自動(單發)
Semi Auto Mode
(Single Shot)

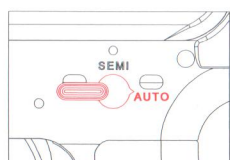

全自動(連發)
Full Auto Mode
(Continuous Shot)

- ③ 扣動扳機即可射擊BB彈。

Pull the trigger.

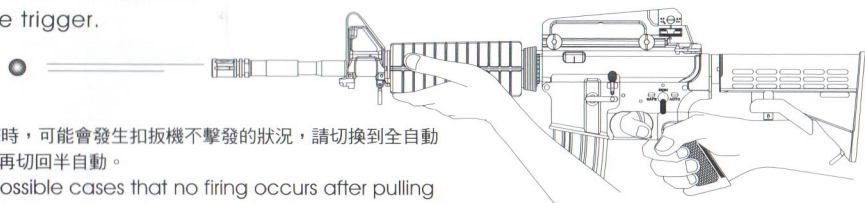

※在半自動射擊時，可能會發生扣扳機不擊發的狀況，請切換到全自動射擊2~3秒後再切回半自動。

There are possible cases that no firing occurs after pulling the trigger in the semi auto mode. fire 2~3 sec in the full auto mode and then return to the semi auto operation.

⚠ 警告 ▪ 注意 WARNING ▪ CAUTION

- 在確認射擊之前，請勿將手指放在扳機上。
Never put your finger on trigger unless you are ready to shoot.
- 裝上彈匣後扣扳機第一發有可能空發，此為正常運作。
A blank firing may occur at triggering after setting the magazine, this is the normal operation of the gun.

8.2 射擊

FIRING

1. 操作結束之後 After Operation

- ◎ 請將氣槍朝向安全方向，卸下彈匣並在半自動模式射擊以清空槍管內的BB彈，最後將射擊選擇鈕切換到安全模式並且同時釋放內部彈簧。
Point the air gun in a safe direction, remove the magazine and fire the gun in semi auto mode to clear the barrel. Then set the selector lever to SAFE mode and the simultaneous release of an internal spring.
- ◎ 彈匣雖已清空或卸下，但可能還有BB彈殘留在槍管內。
Be aware a BB bullet may still be in the barrel after the magazine is removed, or if the magazine empty.

2. 馬達與電池注意事項 Caution on motor and battery

- ◎ 如果循環射數明顯下降時，請將電池取下充電或更換新充電電池。
If the rate of fire noticeably drops, recharge the battery or replace with a fully charged one.
- ◎ 在連續射擊約500發BB彈後，請讓氣槍停止射擊約5~10分鐘，以確保馬達跟電池延長壽命。
Give the air gun a rest for 5 to 10 minutes after firing about 500 rounds, in order to ensure long service life of the motor and battery.

3. 卡彈時的處理 When bullets are clogged

- ◎ 如果發生卡彈，先將彈匣卸下並清除槍管內卡彈，並從彈匣進彈口噴入些許矽油後再恢復射擊，如果問題未改善，請聯繫專賣店維修。
If the BB bullets jammed occurs, remove the magazine, and remove the jammed BB bullets. Apply a few drops of silicone oil into the chamber and resume shooting. if jamming problems persist, contact your nearest authorized dealers for service.

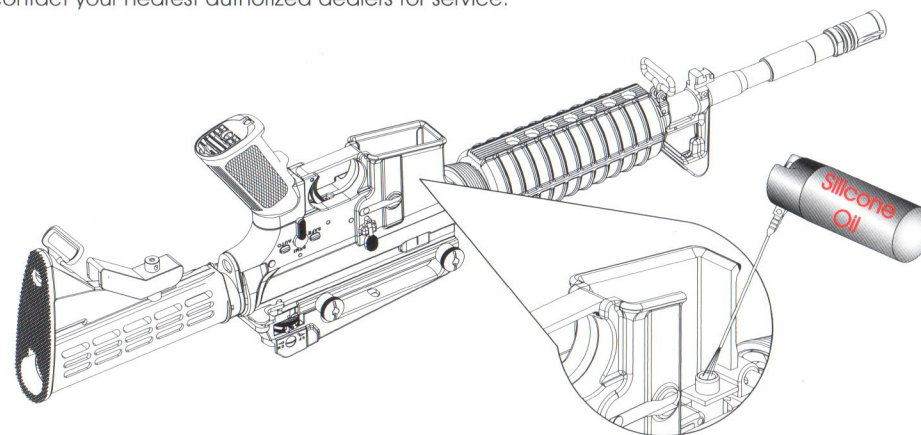

⚠ 警告 ▪ 注意 WARNING ▪ CAUTION

- 請勿使用WD-40, CRC-556或其他礦物油。
Never use WD-40, CRC-556 or other mineral oil.
- 射擊前請注意第2頁的警告事項。
Please read the warning on page 2 before shooting.

9.1 可變上旋(Hop-Up)系統 VARIABLE HOP-UP SYSTEM

※ Hop-Up系統是BB彈經由上方的橡皮施壓讓BB彈擊發後產生自轉而增加彈道飛行距離，調整Hop-Up可以精密調整BB彈自轉的力道使擊發後達到穩定平飛。

By giving rotation of fixed direction to BB bullet, a lift is given and it flies horizontally toward a long distance target. Variable Hop-Up system can tune finely that a spin starts.

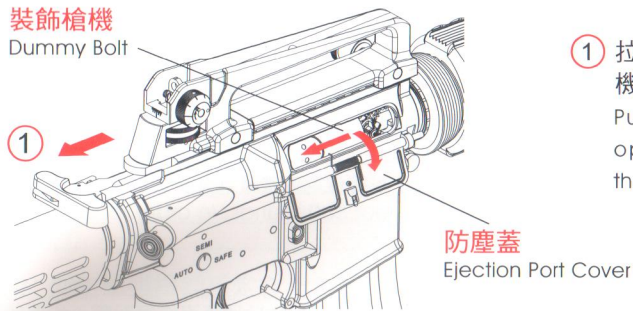

- ① 拉動槍機拉柄可打開防塵蓋，槍機飾片固定在後。
Pulling the Charging handle can opens the Ejection port cover, the dummy bolt will be fixed in rear.

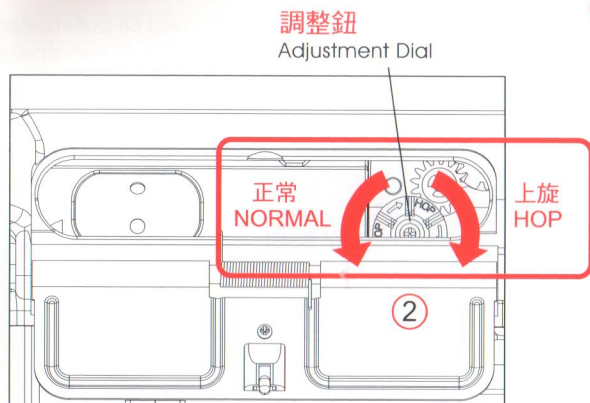

- ② 將調整鈕往上旋的方向旋轉，則可增加彈道飛行距離。
Gradually turn the adjustment dial towards Hop to give hop up to bullets. (The best setting is where bullets fly horizontally.)

※調整過度或不足，會影響彈道的表現。
Turning excessively adversely affects the trajectory. So, stop turning the dial when bullets fly horizontally.

警告 ▪ 注意 WARNING ▪ CAUTION

● 上旋系統調整過度會造成卡彈。如有發生卡彈情形，請立即調回再用半自動模式試射，請勿在卡彈時繼續射擊以免造成氣槍損壞和故障。

Too much hop-Up may cause BB bullet to jam. If a jam occurs, immediately dial back the hop-Up and test fire again in the semi auto mode. Otherwise, damage and malfunctions will occur with the air gun.

● 當調整上旋系統時，小心槍機飾片夾到手指。
Be careful not to catch your fingers in the dummy bolt.

9.2 可變上旋(Hop-Up)系統 VARIABLE HOP-UP SYSTEM

如圖所示，BB彈保持水平彈道為最佳位置，而飛行距離也會增加。

The best position is where the bullets fly horizontally and the longest flying distance is obtained.

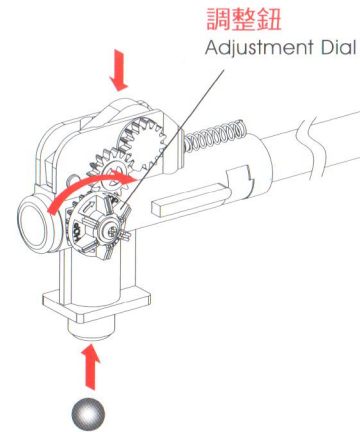
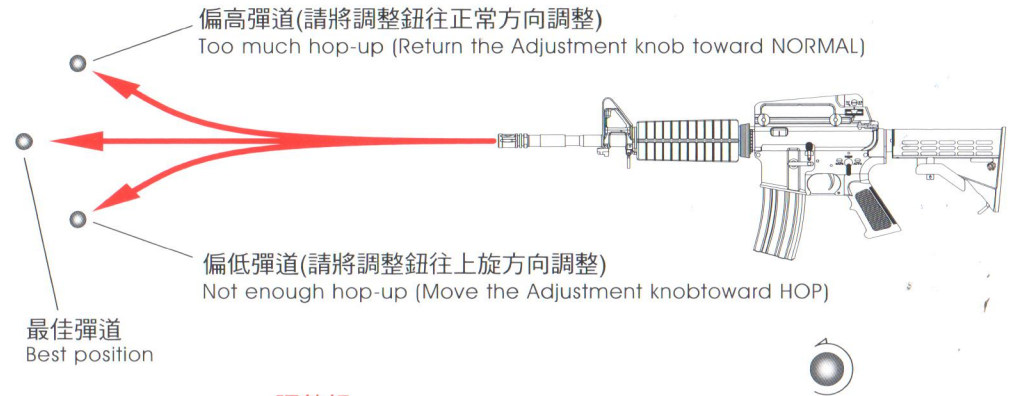

將調整鈕往前調整會使彈道往上飄。
Forward adjustment dial, pellet will float up.

將調整鈕往後調整會使彈道往下墜。
Backward adjustment dial, pellet will fall down.

警告 ▪ 注意 WARNING ▪ CAUTION

● 上旋系統會造成彈道彎曲。若槍傾斜橫著射擊時，BB彈會大幅度往左右飛行而造成危險，所以請保持正常的射擊姿勢。

Never hold the gun sideways as the BB bullets will curve right or left. This is due to the Hop-Up system.

● 當射擊10000發以上，可噴少許矽油在上旋系統內部橡皮進行保養。(約噴0.5~1秒即可)

When about 10,000 rounds are fired, spray silicone oil to the chamber for 0.5 to 1 sec.

10.1 分解圖、零件表

PARTS LIST

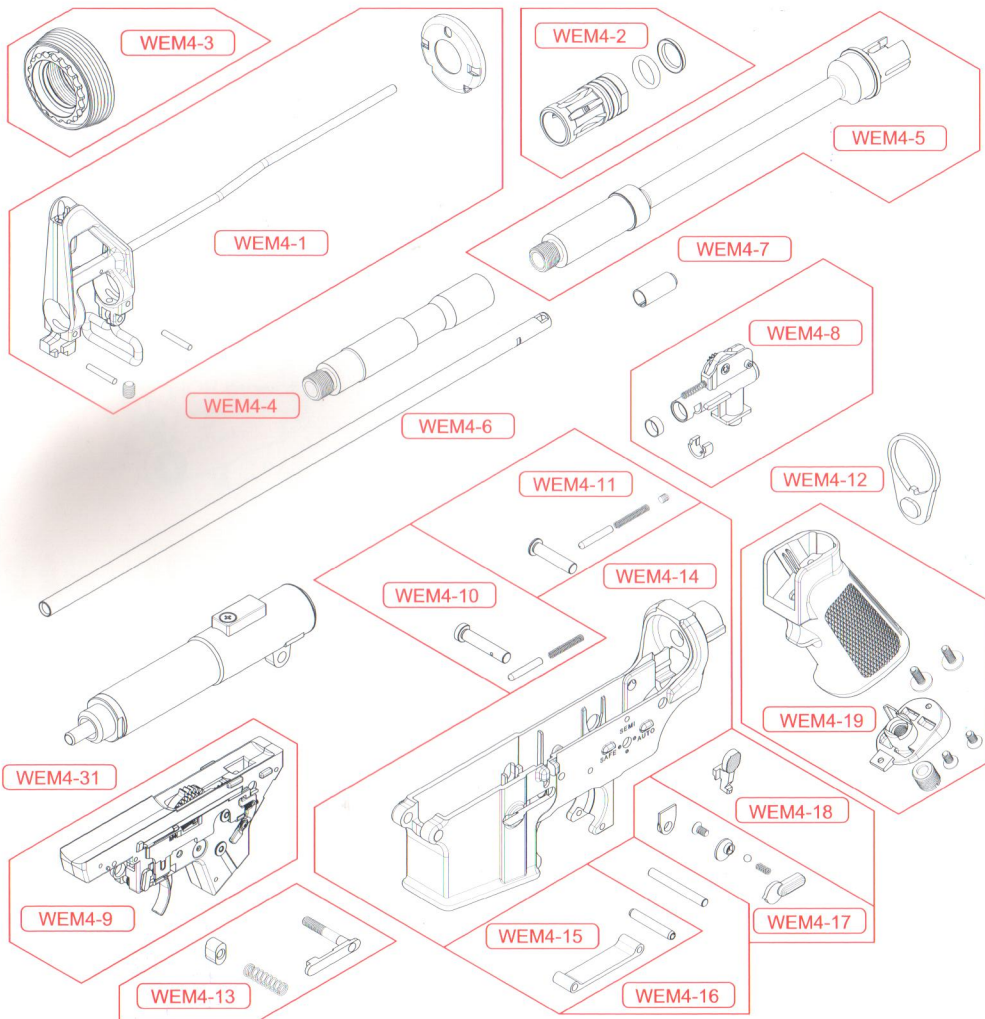

NO.	品名 Parts name	NO.	品名 Parts name
WEM4-1	準星組 Front Sight Set	WEM4-9	齒輪箱組 Gear Box Set
WEM4-2	防火帽組 Flash Hider Set	WEM4-10	前插梢組 Front Pivot Pin Set
WEM4-3	固定環組 Fixing Ring Set	WEM4-11	後插梢組 Rear Pivot Pin Set
WEM4-4	槍管前段 Front Barrel	WEM4-12	槍托連接蓋板 Receiver End Plate
WEM4-5	槍管後段組 Rear Barrel Set	WEM4-13	彈匣卡榫組 Magazine Catch Set
WEM4-6	內槍管 Inner Barrel	WEM4-14	下槍身 Lower Receiver
WEM4-7	上旋系統橡皮 Hop-Up Rubber	WEM4-15	扳機護弓組 Trigger Guard Set
WEM4-8	上旋系統組 Hop-Up Set	WEM4-16	扳機插梢 Trigger Lock Pin

10.2 分解圖、零件表

PARTS LIST

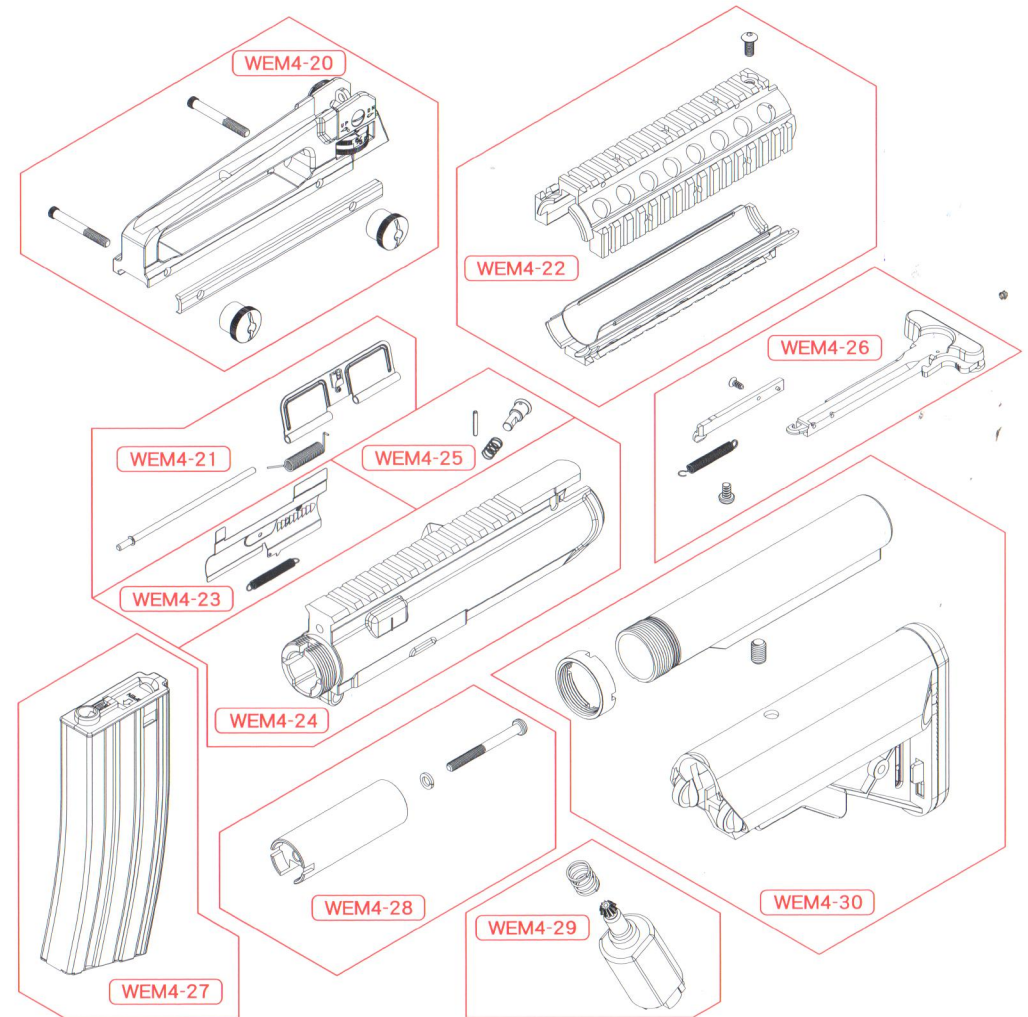

NO.	品名 Parts name	NO.	品名 Parts name
WEM4-17	射擊選擇鈕組 Selector Lever Set	WEM4-25	槍機助進器組 Forward Assist Knob Set
WEM4-18	槍機卡榫 Bolt Catch	WEM4-26	槍機拉柄組 Charging Handle Set
WEM4-19	握把組 Pistol Grip Set	WEM4-27	300發彈匣 300rd Magazine
WEM4-20	提把組 Carrying Handle	WEM4-28	伸縮托桿組 Stock Tube Set
WEM4-21	防塵蓋組 Ejection Port Cover Set	WEM4-29	馬達組 Motor Set
WEM4-22	RIS軌道護木組 RIS Handguards Set	WEM4-30	海軍伸縮托組 Crane stock Set
WEM4-23	槍機節片組 Dummy Bolt Set	WEM4-31	汽缸組 Cylinder Set
WEM4-24	上槍身組 Upper Receiver Set		

10.3 分解圖、零件表

PARTS LIST

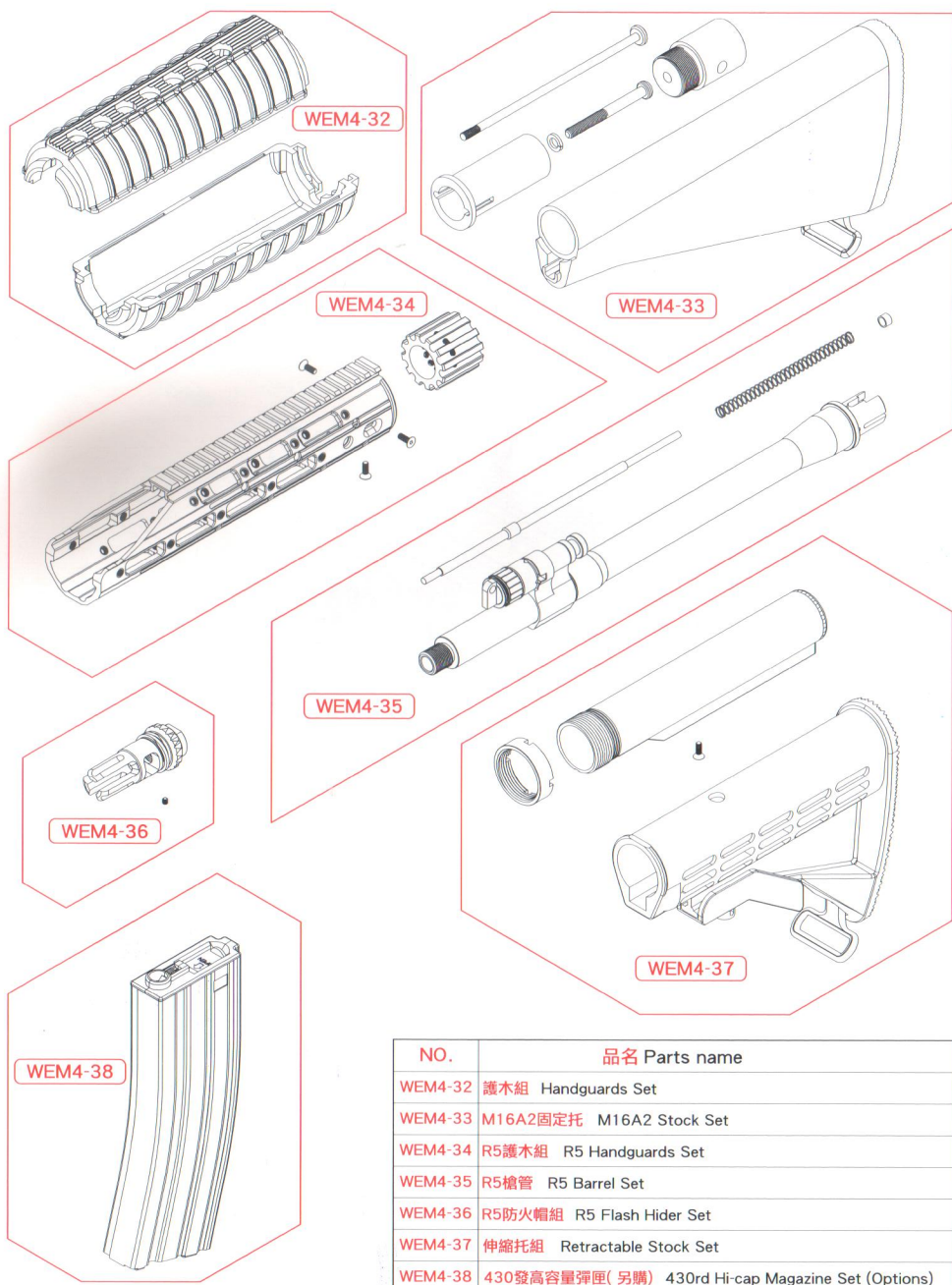

NO.	品名 Parts name
WEM4-32	護木組 Handguards Set
WEM4-33	M16A2固定托 M16A2 Stock Set
WEM4-34	R5護木組 R5 Handguards Set
WEM4-35	R5槍管 R5 Barrel Set
WEM4-36	R5防火帽組 R5 Flash Hider Set
WEM4-37	伸縮托組 Retractable Stock Set
WEM4-38	430發高容量彈匣(另購) 430rd Hi-cap Magazine Set (Options)

11. 故障診斷

TROUBLE CLINIC

狀況 SYMPTOM	原因 CAUSE	處理方式 ACTION
無法作動 No operation at all	選擇鈕設定在SAFE的位置 Selector lever set to SAFE.	將選擇鈕切換到半自動或全自動 Set the selector to AUTO or SEMI.
	電池沒電 Battery is dead.	電池充電 Charge the battery.
	電池接頭脫離 Battery connector is disconnect.	接頭確實接牢 Connect the connector.
	馬達標準壽命已到(約5萬發) Expired the motor life. (about 5 million rounds)	更換馬達 Replace the motor.
	保險絲燒毀 Fuse is blown out.	更換保險絲 Replace the fuse.
馬達有動作卻不能擊發 Motor is revolving but gun doesn't work	齒輪或內部零件損壞 Gear or internal components of damage.	請至專賣店維修 Purchase the replacement parts from the dealer.
	彈匣卡彈 Bullets are clogged in the magazine.	請輕拍彈匣並使用高品質BB彈 Shake the magazine and use high quality BB bullets.
	槍膛卡彈 Bullets are clogged in the chamber.	使用通槍條通出BB彈 Using the cleaning rod to remove the bullet.
單發不正確 Malfunction of semi auto	齒輪正時未對準 Deviation in gear timing.	切換至連發射擊2~3秒後再切回單發 Firing 2~3 sec in the full auto mode and then return to the semi auto.
	單連發撥桿損壞 Cut off lever damage.	請至專賣店維修 Purchase the replacement parts from the dealer.
連發不正確 Malfunction of full auto	齒輪正時未對準 Deviation in gear timing.	切換至單發射擊2~3發後再切回連發 Firing 2~3 shots in the semi auto mode and then return to the full auto.
	單連發撥桿損壞 Cut off lever damage.	請至專賣店維修 Purchase the replacement parts from the dealer.
連發速度變慢 Firing circle slow	電池即將沒電 Deviation in gear timing.	電池充電 Charge the battery.
BB彈飛行距離變短或未擊發時由槍口掉落 Shooting distance becomes shorter or not fired when falls by the muzzle.	上旋系統未調整 Hop-Up system unadjusted.	調整上旋系統 Adjusted the hop-up.
	BB彈不良 Faulty BB bullets.	請使用高品質BB彈(勿使用回收彈) Please use high quality BB bullets. (Do not use the recycling bullets)
作動聲音異常 Overtly loud operating noise	活塞O環磨損 The piston o-ring worn off.	請至專賣店維修 Purchase the replacement parts from the dealer.
	齒輪或內部零件損壞 Gear or internal components of damage.	請至專賣店維修 Purchase the replacement parts from the dealer.