



警告

WARNING

在操作本產品之前，請務必詳讀此說明書
Always read through this manual before operating.

- ★ 正確使用空氣軟槍，可享受愉快的射擊，但是錯誤的使用方法非常危險，務必遵守注意事項。
- Miss handle the airsoft gun may condition serious injure or death. Please read the safety instruction before use.

Caution!

▲ PRECAUTION

NE PAS UTILISER D'AUTRES

PROJECTILEE QUE CEUX FOURNIS.

▲ VORSICHT

Ausschliesslich für diese Pistole bestimmte

Munition verwenden.(6.0mm Kunststoffkugeln)

○ Fare attenzione



★ 射擊時最好戴護目鏡

- Be sure to wear shooting glasses or Goggle when shooting.

▲ Toujours porter des lunettes de tir ou de protection quand vous tirez.

△ Zum Schiessen stets eine Schutzbrille tragen.

■ Asegurese de llevar puestas las gafas de proteccion cuando dispare.

○ Assicursarsi di indossare lenti di Protezione quando si spara



★ 不用時要把槍置於高處 (小孩拿不到的高處)

- Put the gun beyond the reach of kids.

▲ Tenir hors de portee des enfants.

△ Pistole immer kindersicher aufbewahren.

■ Ponga la pistola fuera del alcance de los niños.

○ Tenere fuori Dalla portata dei bambini.



★ 不可用眼睛探視槍

- Don't peep at the muzzle.

▲ Ne jamais regarder dans le canon.

△ Nie in den lauf schauen.

■ Jamas mire por el canon

○ Non guardare mai dentro la canna.



★ 不可朝人射擊

- Don't aim at people even if it is unloaded.

▲ Ne jamais viser quelqu'un meme si votre pistolet est vide.

△ Auch bei spiel-und Sportwaffen besteht Verletzungsgefahr. Auch ungeladen nie auf einen Menschen oder ein Tier richten!

■ No apunte a personas, incluso descargado.

○ Non puntare mai verso le persone anche se la pistola scarica.



★ 射擊的瞬間，才可以把手指接近扳機擊扣

- Don't touch the trigger until the moment of shooting.

▲ Ne jamais appuyer sur la gachette le rearmement.

△ Abzug erst dann berühren,wenn Sie zum Schiessen bereit sind.

■ No toque el gatillo hasta el momento del disparo.

○ Non toccare il grilletto fino al momento di sparare.



★ 確定射擊的方向均安全後才可以射擊

- After making sure that there is nobody nearby.

▲ Toujours etre sur qu'il n y a personne dans la trajectoire de votre tir.

△ Vergewissern Sie sich vor dem Schiessen stets, dass niemand getroffen werden kann.

■ Antes de apuntar aseguese que no hay nadie cerca.

○ Assicursarsi semper che non ci sia nessuno sulla traiettoria di tiro.



★ 避免粗魯的動作，發生危險

- Avoid a rough operation.

▲ Ne jamais jeter le pistolet quand il est arme.

△ Geladene Waffe stets mit Respekt Behandln. Nicht werfen oder unsanft Jandhaben.

■ No tire ni lance la pistola, se puede disparar.

○ Evitare azioni brusche.



★ 不使用時，應將彈匣取出，並取下子彈

- When the gun is not in use, remove the magazine and unload BB pellets.

▲ Quand vous ne l'utilisez plus,bien Faire attention de retirer le chargeur et de le desarmer.

△ Zum Aufbewahren Magazin entfernen und Kugeln herausnehmen.

■ Cuando no se este utilizando la pistola, saque todas las bolas.

○ Quando l'arma non e in uso, estrarre il caricatore e scaricare i pallini.



WE999-SERIES

AUTOMATIC ELECTIC GUN

操作手冊指導手冊

HANDLING CAUTION AND INSTRUCTION MANUAL



WE999-E01
WE999C

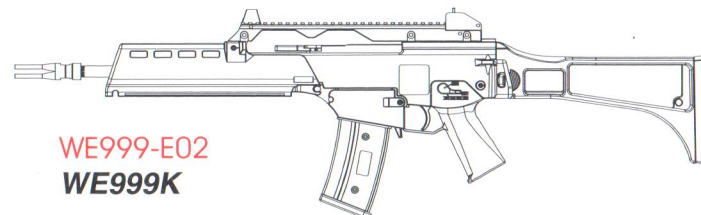

WE999-E02
WE999K

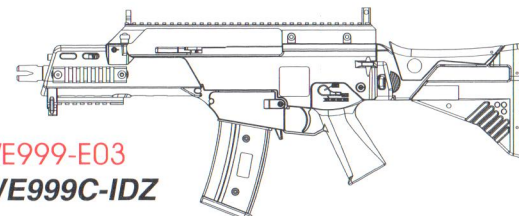

WE999-E03
WE999C-IDZ



WE999-E04
WE999K-IDZ

適合年齡18歲以上使用 User restricted to 18 year of age or older.



注意

WARNING

使用前請務必詳讀此說明書

Always read through this manual before operating.

1. 各部名稱

COMPONENT NAME

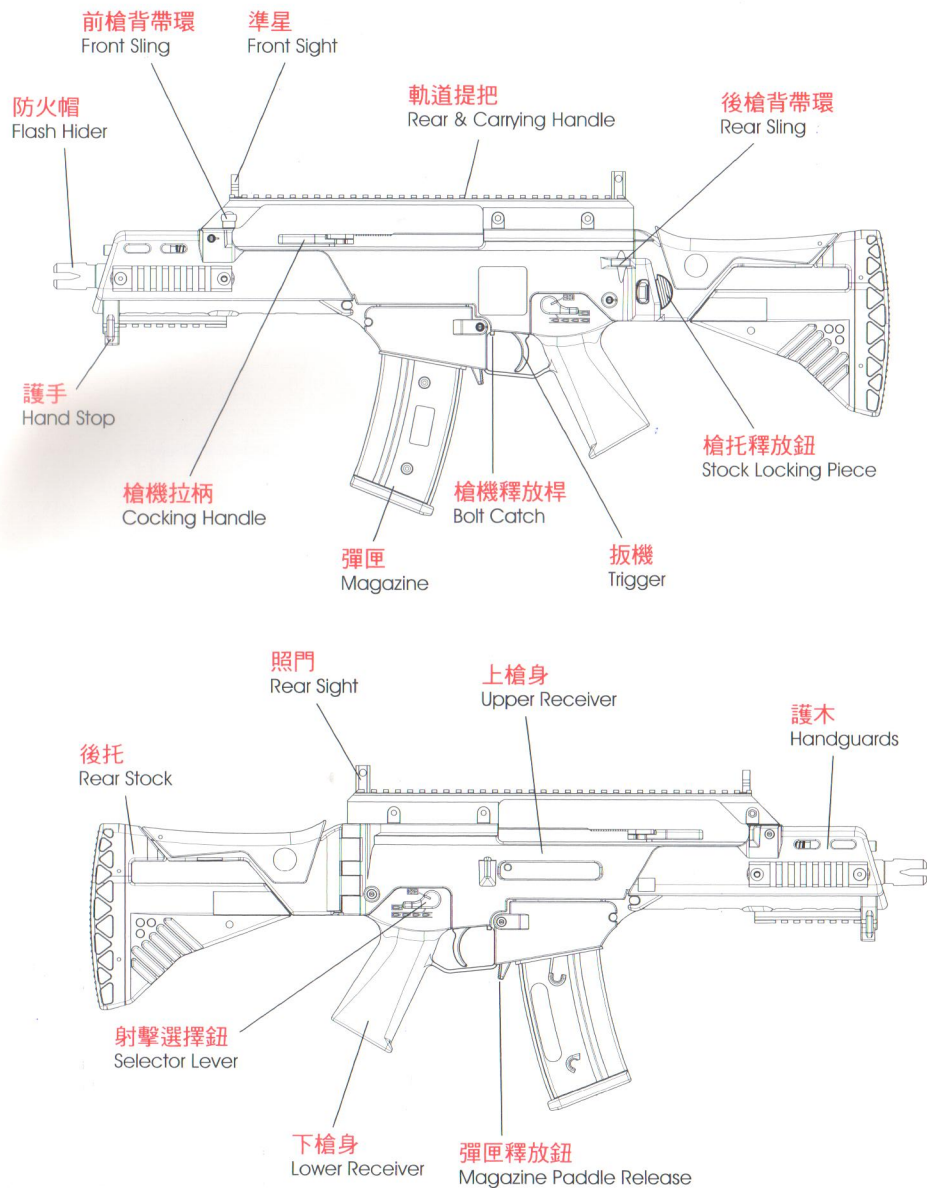

2. 保險說明

SELECTOR LEVER & SAFETY SETTING

※ 選擇鈕未扳至正確位置有可能會導致射擊模式發生錯誤。

Set the selector correctly in position, otherwise, malfunction may occur.

1. 保險(無法扣動扳機)

不射擊或一般存放時，務必將選擇鈕設定至保險()位置。

Safety setting(The trigger can not be pull)

Always set lever to the safe() position when you are not firing the gun or during storage.

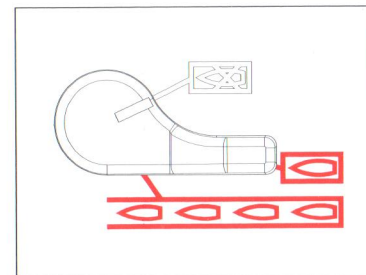

2. 半自動(單發)

選擇鈕設定至半自動()位置，此時扣一次扳機只會發射一顆子彈。

Semi Auto(Single Shot)

Set lever to the semi() position, The gun will fire one shot each time the trigger is pulled.

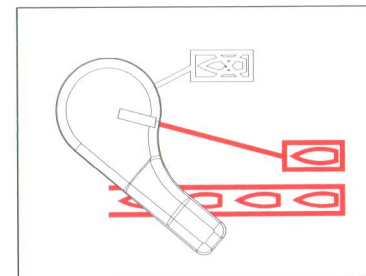

3. 全自動(連發)

選擇鈕設定至全自動()位置，此時扣扳機不放會連續發射子彈。

Full Auto(Automatic Shot)

Set lever to the auto() position, The gun will fire automatically while the trigger remains pulled.

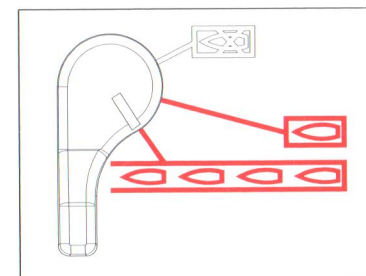

警告 · 注意 WARNING · CAUTION

- 請勿一邊扣動扳機一邊扳動選擇鈕，否則將導致故障，或發生意外。
Never operation the Selector while pulling the trigger. Otherwise malfunctions are possible, resulting in accidents.
- 在關保險狀態時，強制扣動扳機有可能會導致故障。
Pulling the trigger with the Selector being set to safe may damage the gun.

3. 電池的安裝

SETTING BATTERY

1. 將護木固定插銷卸下，並插入槍托的孔內防止遺失。
Remove handguard lock pin, put it into the hold on the stock to prevent missing.
2. 將護木往前抽出。
Remove the handguard.



2. 將電池放入護木並接好接頭。
Put the battery into the handguard and connect the connector.

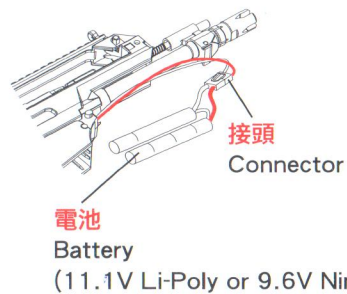

3. 將護木蓋回並插入護木固定銷。
Put the handguard back and insert handguard lock pin.

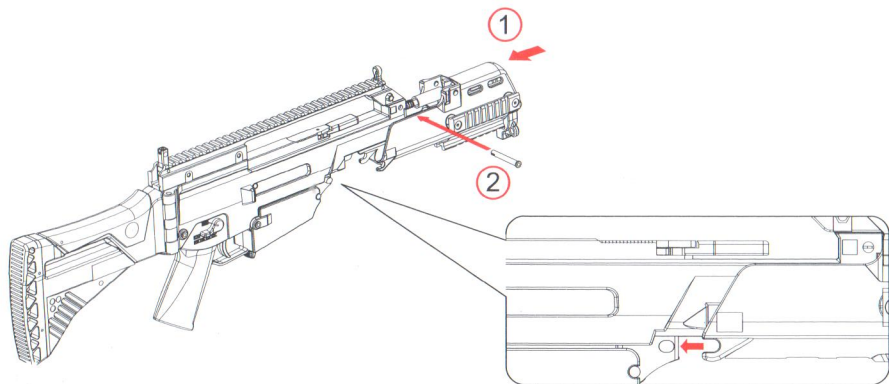

⚠ 警告·注意 WARNING·CAUTION

- 電池必須先行充電完畢。
The battery must be fully charged.
- 電池安裝時，請將槍口朝向安全的位置，並將選擇鈕設定於保險位置。
When the battery is installed, place the muzzle toward the safety position, and set the selector lever to the safety position.

4. 彈匣的安裝

SETTING MAGAZINE

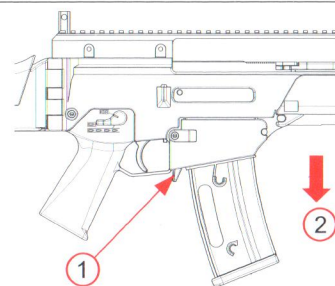

1. 按壓彈匣釋放鈕。
Press the Magazine paddle release.
2. 取下彈匣。(取下時請扶住彈匣，避免彈匣掉下損壞。)
Remove the magazine. (Support the magazine as it may drop.)



3. 將彈匣蓋打開並倒入BB彈。
Open the cover of magazine and insert BBs in to the magazine.



4. 轉動底部轉盤依箭頭方向將發條上緊直到聽到“喀喀”聲時則停止轉動。
Turn the gear at the bottom until heard click sound.

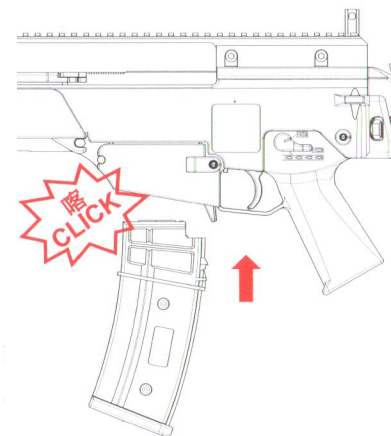

5. 正確將彈匣向上插入彈匣口連接牢固直到聽到“喀”一聲。
Make sure to set the magazine upwards and connect it firmly until heard a click sound.

⚠ 警告·注意 WARNING·CAUTION

- 請使用高品質BB彈在你的槍上，對因使用劣質或重量不足的BB彈產生的損壞件，本公司將不負保固責任。
Always use the high quality BB bullets in your air gun. We will not be held responsible for any damage incidents arising from use of poor quality or underweight BB bullets.

5. 準星與照門的使用說明

FRONT SIGHT AND REAR SIGHT INSTRUCTIONS FOR USE

準星的使用

Use of the Front Sight.

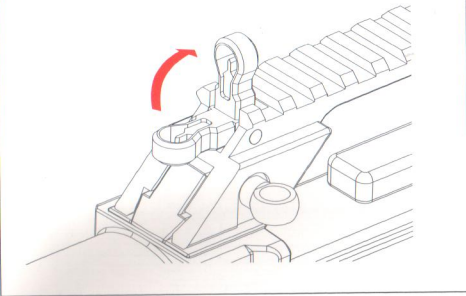

照門的使用

Use of the Rear Sight.

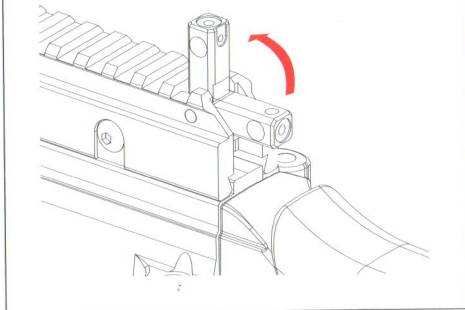

6.1 可動部的說明

MOVABLE PARTS

槍機拉柄與槍機釋放桿操作

Operate the Charging Handle and Bolt Catch.

1. 將槍機拉柄向後拉，拋殼窗會打開。
Pulling the Cocking handle can opens the Ejection port.

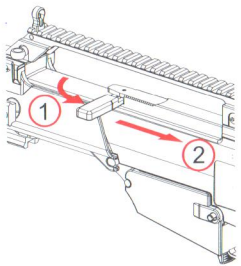

2. 按壓槍機卡榫可將槍機固定在後。
Press Bolt Catch the bolt will be fixed in the rear.

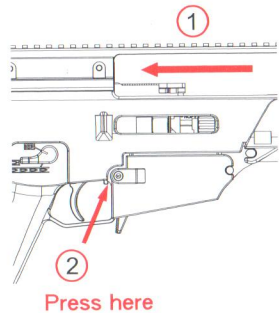

3. 將槍機拉柄向後拉可使槍機回位。
Pulling the Cocking handle can back off the bolt.

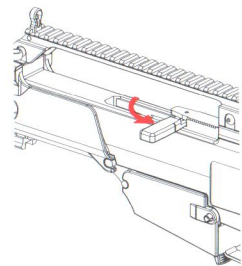

6.2 可動部的說明

MOVABLE PARTS

伸縮托操作 Operate the Telescoping Stock.

1. 調整貼腮板位置(三段可調)
Pressing the cheek piece button can adjust the position of cheek piece. (3 levels adjustment)

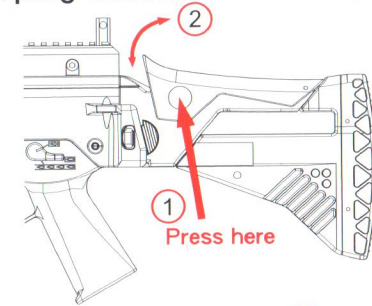

2. 調整槍托長度(六段可調)
Pressing the retractable button can adjust stock length. (6 levels adjustment)

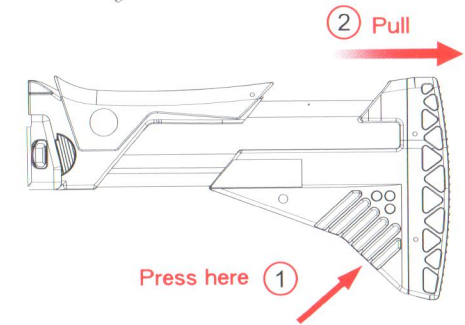

3. 摺疊槍托
Pushing the Stock locking piece can fold the stock.

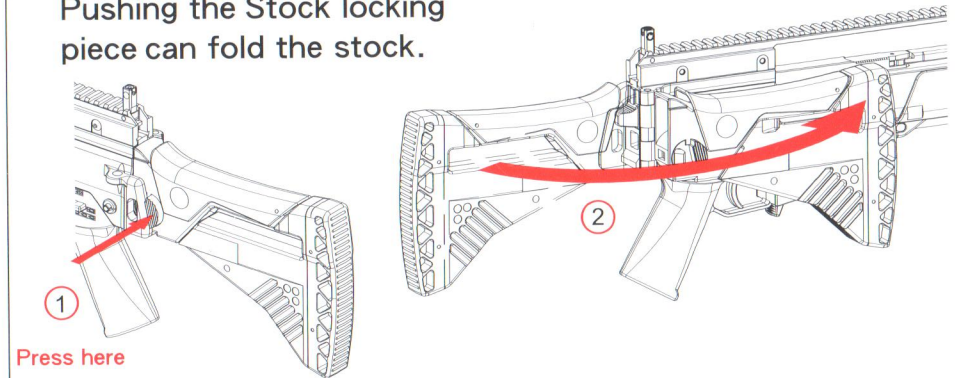

警告 · 注意 WARNING · CAUTION

- 操作伸縮托時，請小心勿被夾傷。
Be carefully don't get hurt your fingers when operating stock functions.

7.1 射擊

FIRING

※充分確認安全後才可開始進行射擊。

Confirm safety sufficiently before beginning firing.

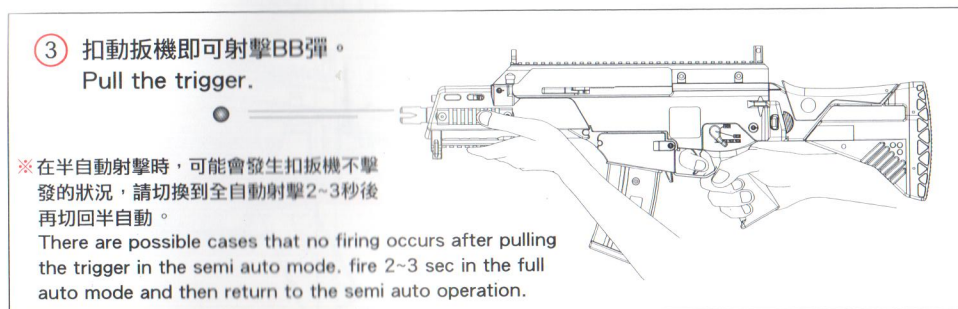
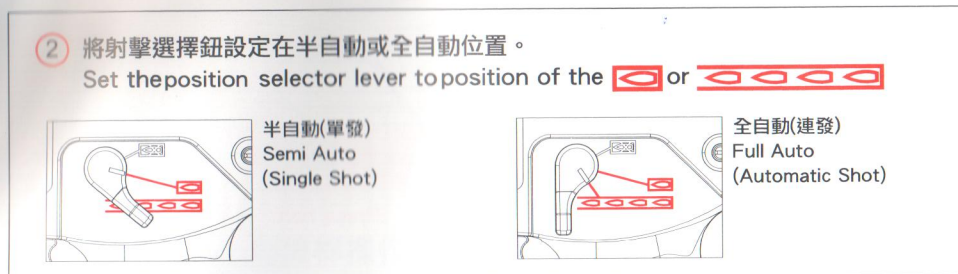
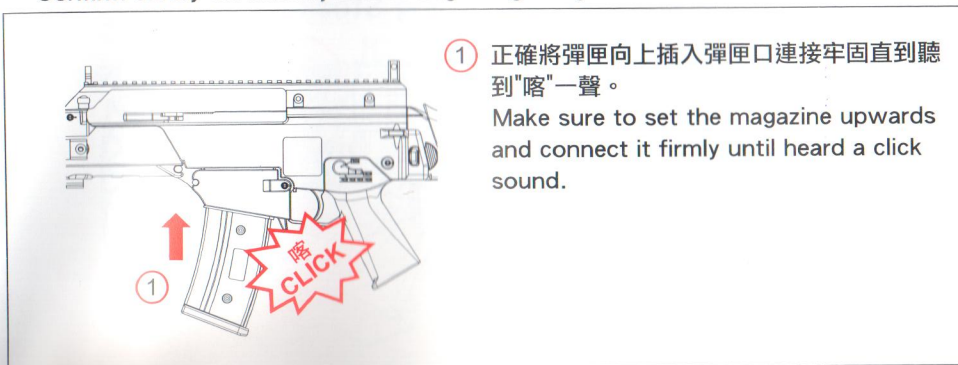

警告・注意 WARNING・CAUTION

- 在確認射擊之前，請勿將手指放在扳機上。
Never put your finger on trigger unless you are ready to shoot.
- 裝上彈匣後扣扳機第一發有可能空發，此為正常運作。
A blank firing may occur at triggering after setting the magazine, this is the normal operation of the gun.

7.2 射擊

FIRING

1. 操作結束之後 After Operation

- ◎ 請將氣槍朝向安全方向，卸下彈匣並在半自動模式射擊以清空槍管內的BB彈，最後將射擊選擇鈕切換到安全模式並且同時釋放內部彈簧。
Point the air gun in a safe direction, remove the magazine and fire the gun in semi auto mode to clear the barrel. Then set the selector lever to SAFE mode and the simultaneous release of an internal spring.
- ◎ 彈匣雖已清空或卸下，但可能還有BB彈殘留在槍管內。
Be aware a BB bullet may still be in the barrel after the magazine is removed, or if the magazine empty.

2. 馬達與電池注意事項 Caution on motor and battery

- ◎ 如果循環射數明顯下降時，請將電池取下充電或更換新充電電池。
If the rate of fire noticeably drops, recharge the battery or replace with a fully charged one.
- ◎ 在連續射擊約500發BB彈後，請讓氣槍停止射擊約5~10分鐘，以確保馬達跟電池延長壽命。
Give the air gun a rest for 5 to 10 minutes after firing about 500 rounds, in order to ensure long service life of the motor and battery.

3. 卡彈時的處理 When bullets are clogged

- ◎ 如果發生卡彈，先將彈匣卸下並清除槍管內卡彈，並從彈匣進口噴入些許矽油後再恢復射擊，如果問題未改善，請聯繫專賣店維修。
If the BB bullets jammed occurs, remove the magazine, and remove the jammed BB bullets. Apply a few drops of silicone oil into the chamber and resume shooting. If jamming problems persist, contact your nearest authorized dealers for service.

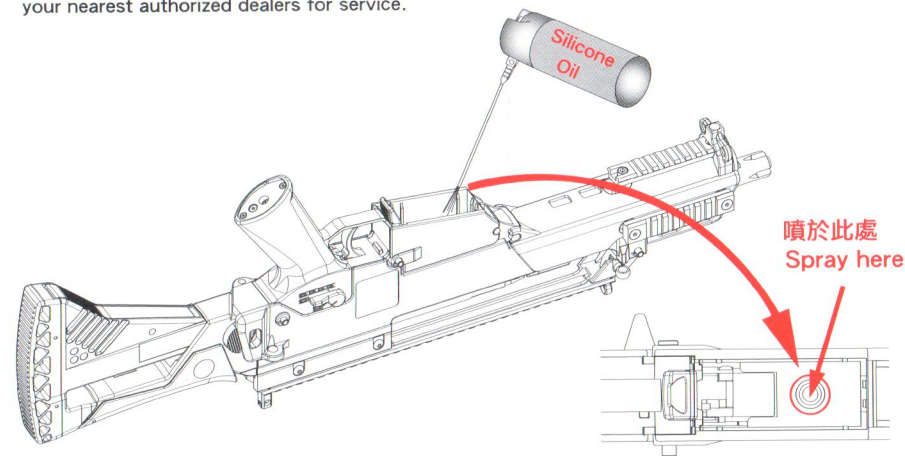

警告・注意 WARNING・CAUTION

- 請勿使用WD-40, CRC-556或其他礦物油。
Never use WD-40, CRC-556 or other mineral oil.
- 射擊前請注意第2頁的警告事項。
Please read the warning on page 2 before shooting.

8.1 可變上旋(Hop-Up)系統 VARIABLE HOP-UP SYSTEM

※ Hop-Up系統是BB彈經由上方的橡皮施壓讓BB彈擊發後產生自轉而增加彈道飛行距離，調整Hop-Up可以精密調整BB彈自轉的力道使擊發後達到穩定平飛。

By giving rotation of fixed direction to BB bullet, a lift is given and it flies horizontally toward a long distance target. Variable Hop-Up system can tune finely that a spin starts.

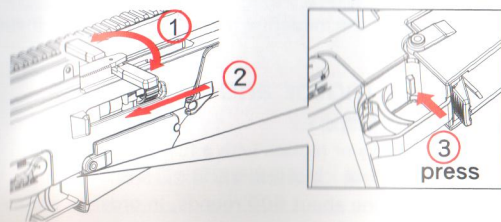

1 拉動槍機拉柄可打開拋殼口，按壓槍機卡榫可將槍機固定在後。
Pulling the Cocking Handle can opens the Ejection port, Press Bolt Catch the bolt will be fixed in the rear.

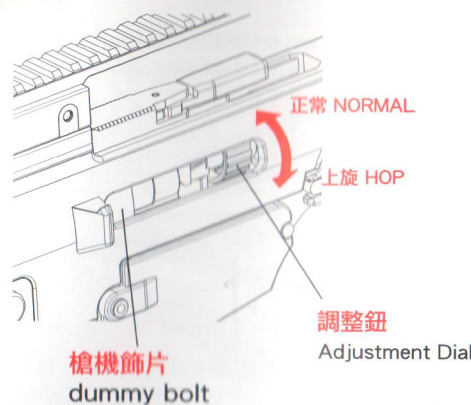

2 將調整鈕往上旋的方向旋轉，則可增加彈道飛行距離。
Gradually turn the adjustment dial towards Hop to give hop up to bullets. (The best setting is where bullets fly horizontally.)

※ 調整過度或不足，會影響彈道的表現。
Turning excessively adversely affects the trajectory. So, stop turning the dial when bullets fly horizontally.

警告 · 注意 WARNING · CAUTION

- 上旋系統調整過度會造成卡彈。如有發生卡彈情形，請立即調回再用半自動模式試射，請勿在卡彈時繼續射擊以免造成氣槍損壞和故障。

Too much Hop-Up may cause BB bullet to jam. If a jam occurs, immediately dial back the Hop-Up and test fire again in the semi auto mode. Otherwise, damage and malfunctions will occur with the air gun.

- 當調整上旋系統時，小心槍機飾片夾到手指。

Be careful not to catch your fingers in the dummy bolt.

8.2 可變上旋(Hop-Up)系統 VARIABLE HOP-UP SYSTEM

如圖所示，BB彈保持水平彈道為最佳位置，而飛行距離也會增加。

The best position is where the bullets fly horizontally and the longest flying distance is obtained.

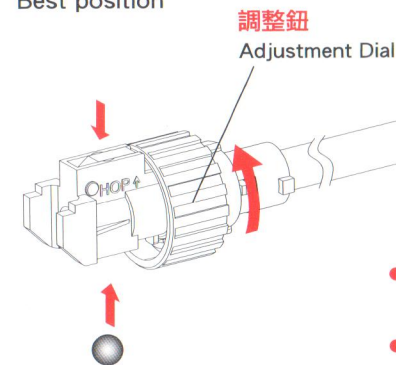
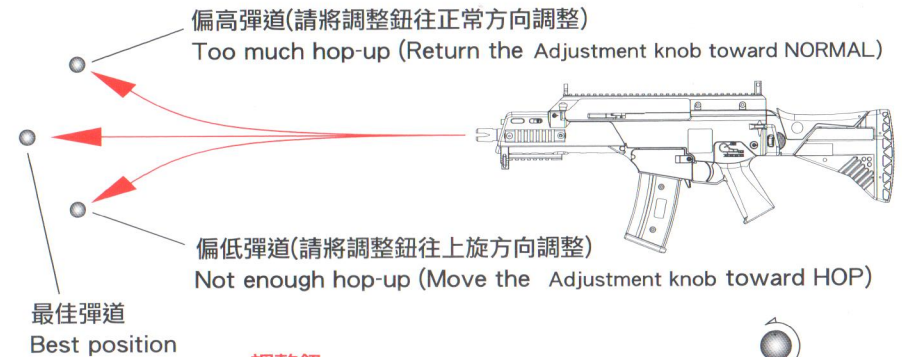

- 將調整鈕往前調整會使彈道往上飄。
Forward adjustment dial, pellet will float up.
- 將調整鈕往後調整會使彈道往下墜。
Backward adjustment dial, pellet will fall down.

警告 · 注意 WARNING · CAUTION

- 上旋系統會造成彈道彎曲。若槍傾斜橫著射擊時，BB彈會大幅度往左右飛行而造成危險，所以請保持正常的射擊姿勢。

Never hold the gun sideways as the BB bullets will curve right or left. This is due to the Hop-Up system.

- 當射擊10000發以上，可噴少許矽油在上旋系統內部橡皮進行保養。(約噴0.5~1秒即可)

When about 10,000 rounds are fired, spray silicone oil to the chamber for 0.5 to 1 sec.

9.1 分解圖、零件表

PARTS LIST

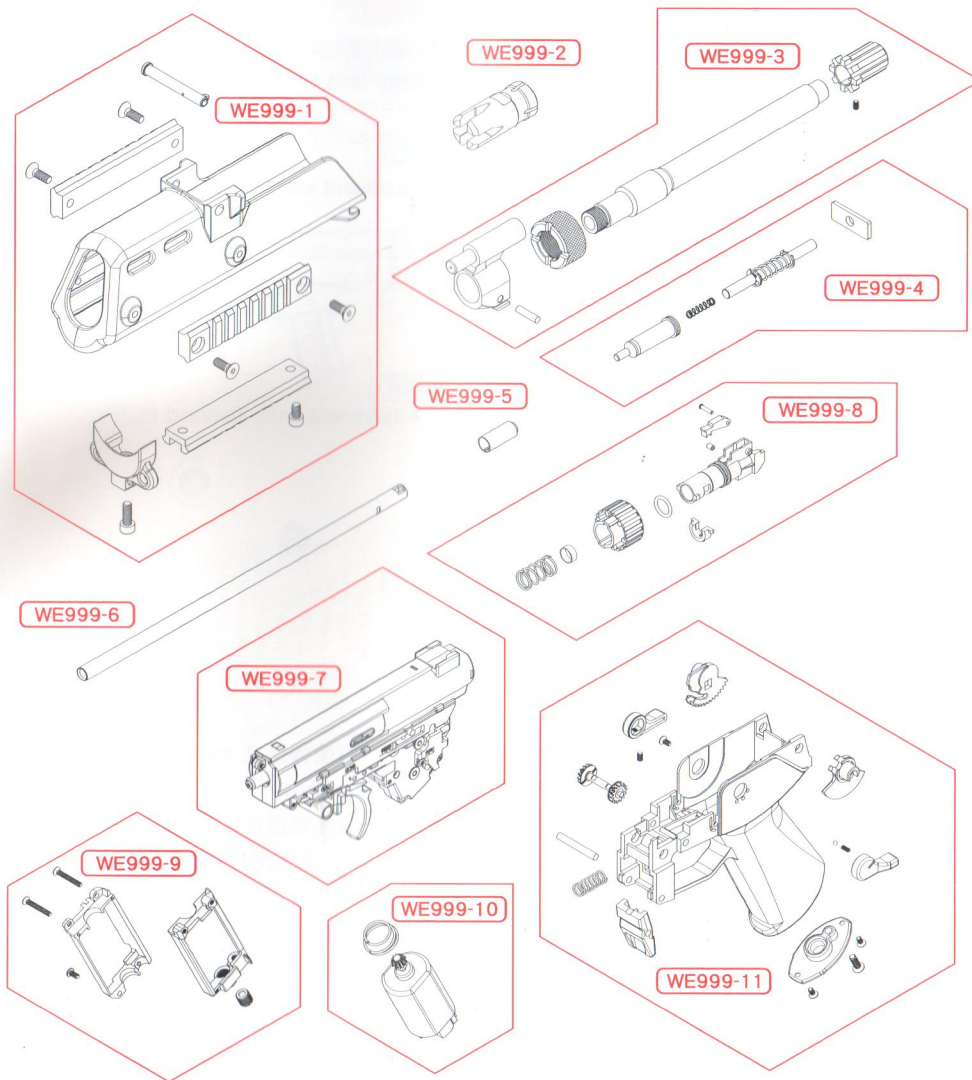

NO.	品名 Parts name
WE999-1	護木組 Handguards Set
WE999-2	防火帽 Flash Hider
WE999-3	槍管組 Barrel Set
WE999-4	瓦斯活塞桿組 Gas Piston Rod Set
WE999-5	上旋系統橡皮 Hop-Up Rubber
WE999-6	內槍管 Inner Barrel

NO.	品名 Parts name
WE999-7	齒輪箱組 Gear Box Set
WE999-8	上旋系統組 Hop-Up Set
WE999-9	馬達座組 Motor Frame Set
WE999-10	馬達組 Motor Set
WE999-11	下槍身 Lower Receiver

9.2 分解圖、零件表

PARTS LIST

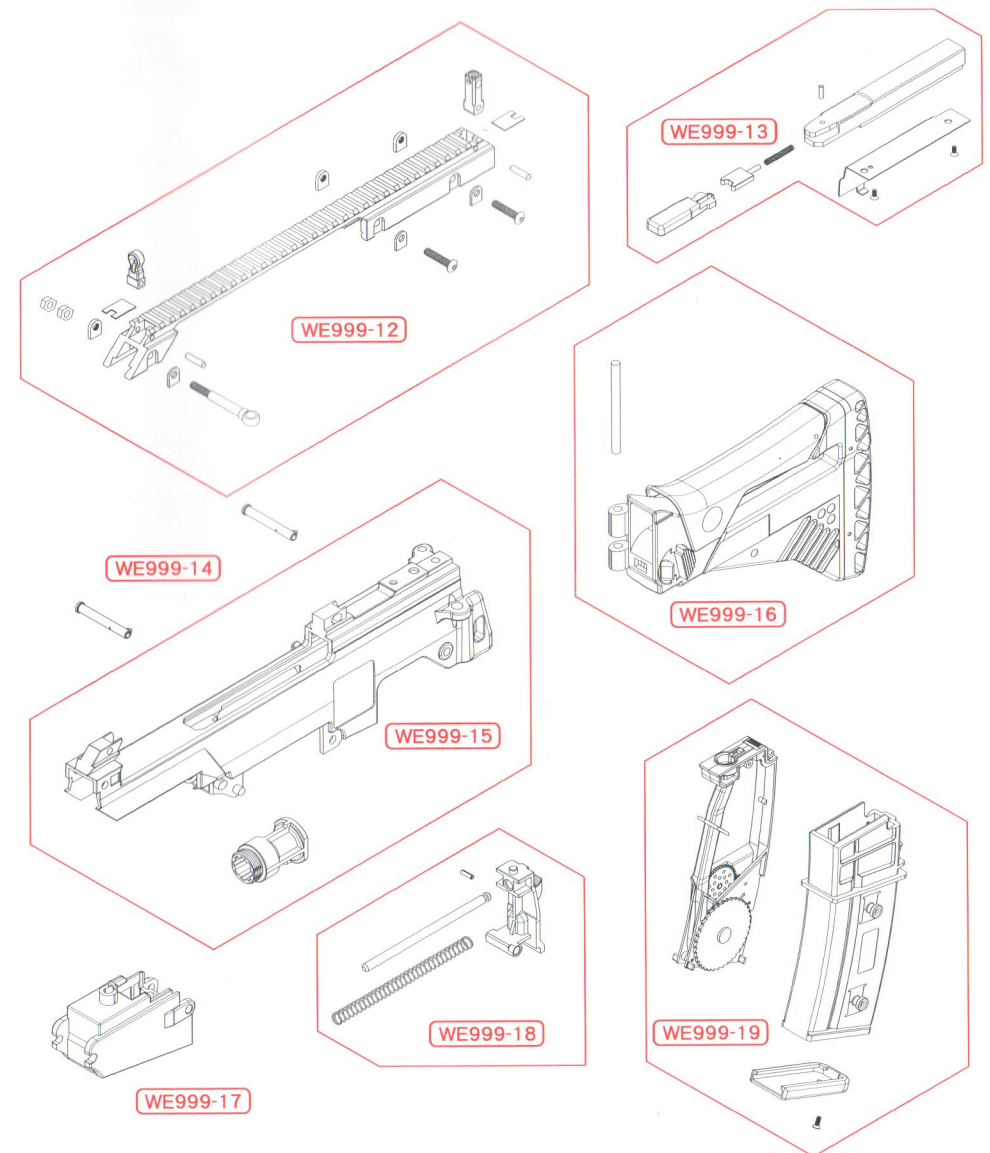

NO.	品名 Parts name
WE999-12	IDZ瞄具軌道組 IDZ Sight Rail Set
WE999-13	槍機組 Bolt Set
WE999-14	插梢組 Push Pin Set
WE999-15	上槍身組 Upper Receiver Set

NO.	品名 Parts name
WE999-16	IDZ托組 IDZ Folding Stock
WE999-17	彈匣井 Magazine Well
WE999-18	覆進簧座組 Recoil Rod Housing Set
WE999-19	470發彈匣 470rd Magazine

9.3 分解圖、零件表

PARTS LIST

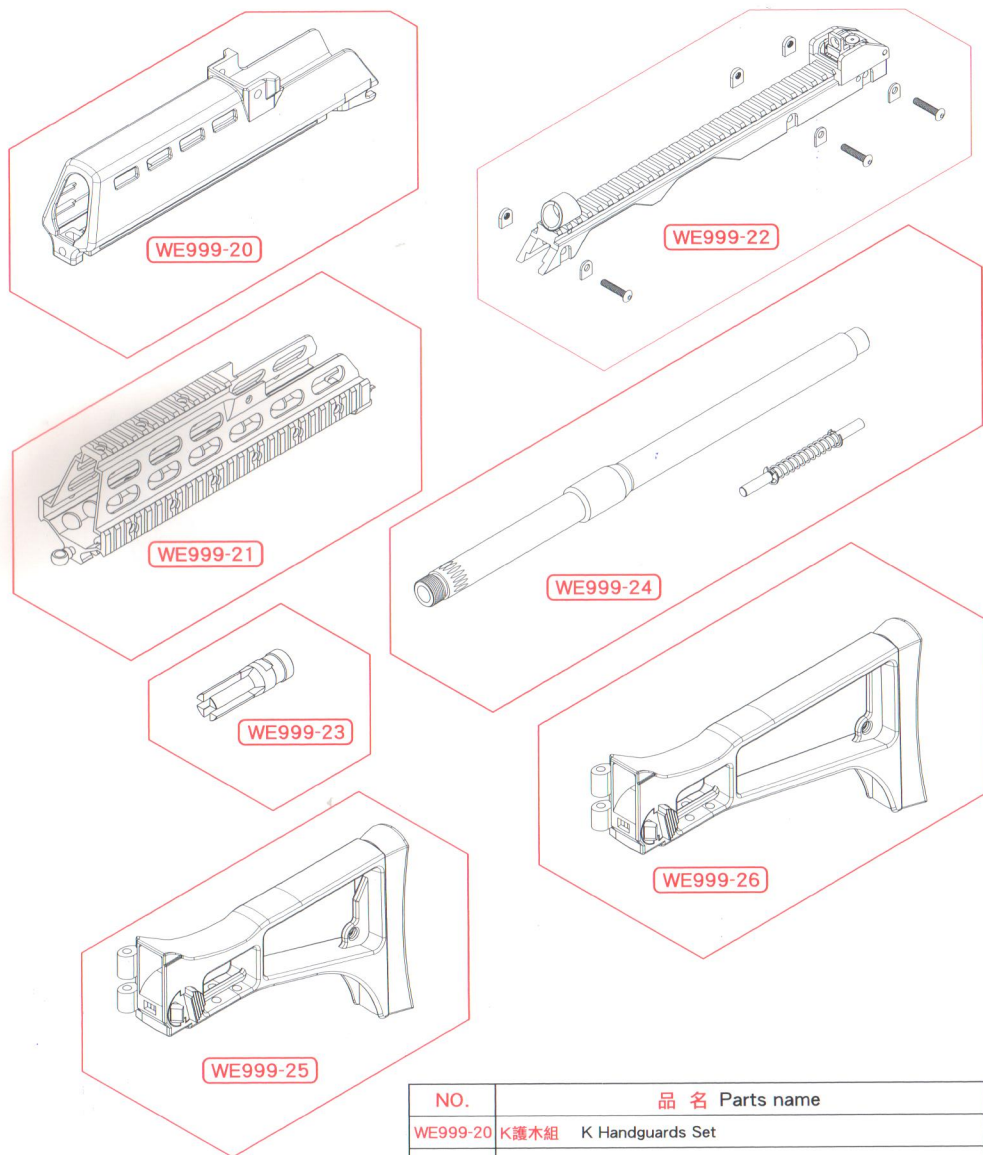

NO.	品名 Parts name
WE999-20	K護木組 K Handguards Set
WE999-21	RAS護木組 RAS Handguards Set
WE999-22	瞄具軌道組 Sight Rail Set
WE999-23	K防火帽 K Flash Hider
WE999-24	K槍管組 K Barrel Set
WE999-25	C後托組 C Rear Stock Set
WE999-26	K後托組 K Rear Stock Set

10. 故障診斷

TROUBLE CLINIC

狀況 SYMPTOM	原因 CAUSE	處理方式 ACTION
無法作動 No operation at all	選擇鈕設定在SAFE的位置 Selector lever set to SAFE.	將選擇鈕切換到半自動或全自動 Set the selector to AUTO or SEMI.
	電池沒電 Battery is dead.	電池充電 Charge the battery.
	電池接頭脫離 Battery connector is disconnect.	接頭確實接牢 Connect the connector.
	馬達標準壽命已到(約5萬發) (about 5 million rounds)	更換馬達 Replace the motor.
馬達有動作卻不能擊發 Motor is revolving but gun doesn't work	保險絲燒毀 Fuse is blown out.	更換保險絲 Replace the fuse.
	齒輪或內部零件損壞 Gear or internal components of damage.	請至專賣店維修 Purchase the replacement parts from the dealer.
	彈匣卡彈 Bullets are clogged in the magazine.	請輕拍彈匣並使用高品質BB彈 Shake the magazine and use high quality BB bullets.
單發不正確 Malfunction of semi auto	槍膛卡彈 Bullets are clogged in the chamber.	使用通槍條通出BB彈 Using the cleaning rod to remove the bullet.
	齒輪正時未對準 Deviation in gear timing.	切換至連發射擊2~3秒後再切回單發 Firing 2 ~3 sec in the full auto mode and then return to the semi auto.
連發不正確 Malfunction of full auto	單連發撥桿損壞 Cut off lever damage.	請至專賣店維修 Purchase the replacement parts from the dealer.
	齒輪正時未對準 Deviation in gear timing.	切換至單發射擊2~3發後再切回連發 Firing 2 ~3 shots in the semi auto mode and then return to the full auto.
連發速度變慢 Firing circle slow	單連發撥桿損壞 Cut off lever damage.	請至專賣店維修 Purchase the replacement parts from the dealer.
BB彈飛行距離變短或未擊發時由槍口掉落 Shooting distance becomes shorter or not fired when falls by the muzzle.	電池即將沒電 Deviation in gear timing.	電池充電 Charge the battery.
	上旋系統未調整 Hop-Up system unadjusted.	調整上旋系統 Adjusted the hop-up.
作動聲音異常 Overly loud operating noise .	BB彈不良 Faulty BB bullets.	請使用高品質BB彈(勿使用回收彈) Please use high quality BB bullets. (Do not use the recycling bullets)
	活塞O環磨損 The piston o-ring worn off.	請至專賣店維修 Purchase the replacement parts from the dealer.
作動聲音異常 Overly loud operating noise .	齒輪或內部零件損壞 Gear or internal components of damage.	請至專賣店維修 Purchase the replacement parts from the dealer.